

**HYDRAULIC AND MECHANICAL  
HINGED LIP LEVELLERS**

**RITE·HITE®**

**Loading dock  
systems with  
technology...**



**Dock levellers  
with hinged lip**

**Models**

**7000** (mechanical)

**8000** (hydraulic)



## Pit details

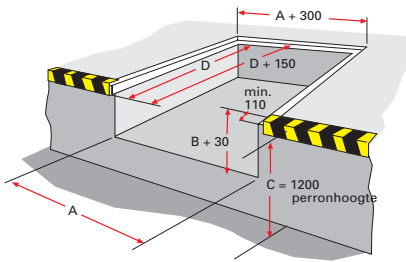

### Option 1

Hang in frame for open and closed pit construction, see detail "A".

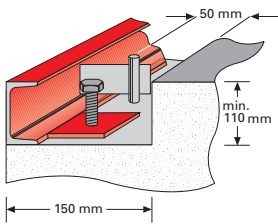

### Detail "A"

Adjustment bolt for adjustment of the level between leveller and floor during installation. Groove spacing (15 x 10 cm) with mounting pins in concrete.

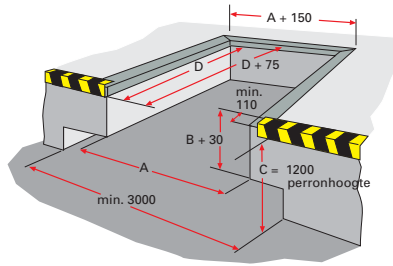

### Option 2

Curb angle for easy installation of levellers in closed pits and open pit constructions with additional recessed space for tail lifts, see detail "B".

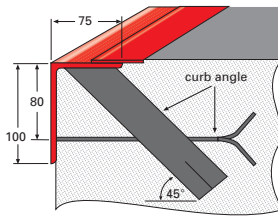

### Detail "B"

Curb angle pit construction (100 x 75 x 7 mm). Leveller frame is welded on the curb angle.

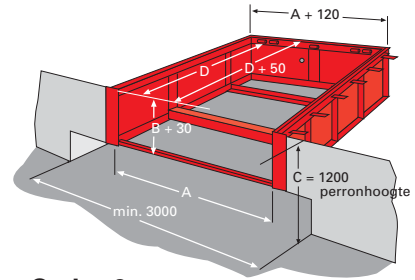

### Option 3

Pour in pan construction. Levellers can be installed after concrete has been poured.

Other leveller frame models available on request

The leveller will be delivered fully assembled, placed in the pit with a crane and welded in place.

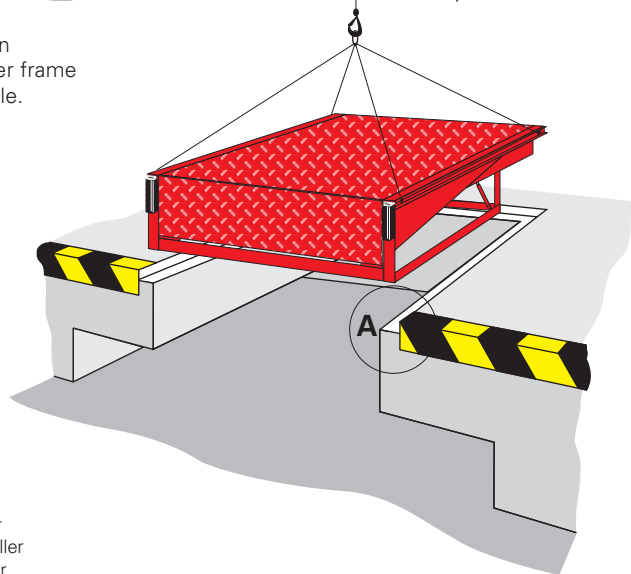

D=Nominal length (mm)	Nominal width (mm)					B=Pit depth (mm)		
	1500	1750	2000	2250	2400	CHKB-S	CMKB-S	CHVB-S
	A=Pit width (mm)							
2000						620	620	720
2500						620	620	720
3000	1560	1810	2060	2310	2460	700	700	820
3500						700	-	900
4000						700	-	900
4500						700	-	900

**CHKB-S** = Hydraulic Hinged lip leveller  
**CMKB-S** = Mechanical Hinged lip leveller  
**CHVB-S** = Hydraulic Telescopic leveller



## RITE-HITE

Koppelstraat 23  
 NL-7391 AK Twello  
 Netherlands

Phone + 31 (0) 571 - 27 04 44  
 Fax + 31 (0) 571 - 27 05 55  
 e-mail: info@ritehite.nl

internet:  
[www.ritehite.com](http://www.ritehite.com)  
[www.caljanritehite.com](http://www.caljanritehite.com)



For UK Contact: **CALJAN RITE-HITE UK**

Moorbridge Road  
 Bingham Industrial Estate  
 Bingham Nottingham  
 NG 13 8GG, United Kingdom

Phone + 44 19 49 83 88 50  
 Fax + 44 19 49 83 69 53  
 e-mail: caljanritehite@caljanritehite.co.uk

## RITE-HITE

### Hinged lip leveller CMKB-S 7000

### Hinged lip leveller CHKB-S 8000



Part of a large project including Modell 8000 hinged lip leveller, Model 5000 dock shelter and Model 6000 sectional doors

#### Technical description

##### CHKB-S 8000:

The deck plate of the Rite-Hite hinge lip leveller consists of an anti-slip, 8 mm diamond tread plate and is reinforced with welded beams under the deck. The framed platform is easily interchanged should requirements change. The leveller frame can be delivered, installed and poured in concrete independent of the platform. After completion of the pit, the platform can be installed in the pre installed frame. Due to the shallow depth of the leveller and the self carrying structure of the frame, servicing tail gates is possible.

##### CHKB-S 8000 Safety features:

- Emergency stop system throughout the full working range
- Extremely stable in case of emergencies
- Dual lifting cylinders are provided with a free fall protection in cases of early departure with a load on the platform
- Full range toe guards (8 mm) with painted yellow/black stripes

##### CHKB-S 8000

##### Control box:

The micro processor controls can be adjusted based on customer requirements, to include options such as interconnects between the dock leveller and the sectional door or integrated sectional door controls.

##### Standard controls:

- Automatic return to dock position
- Reset Lock after emergency stop
- Platform Locking at power failure
- Enclosure protection IP 54 acc. to Din 40050

The whole leveller package is in accordance with the European standard EN 1398. All operators controls are mounted in a gasketed enclosure and comply with the harmonized standards (EN-60204-1). All electrical components, connections and wiring are CE listed or recognized.



Example of a control box

##### CHKB-S 8000 Hydraulics:

The platform is raised by two lifting cylinders. Both lift cylinders incorporate built in velocity fuses to ensure emergency stop capability. The hinged lip is extended by a double acting cylinder. Biodegradable hydraulic oil can be used.



Working range -30° til +80°C

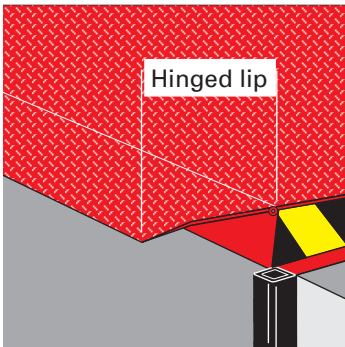

Hinged lip dock leveller with 400 mm lip length

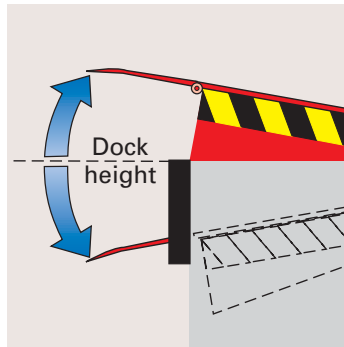

Operating range above and below dock height

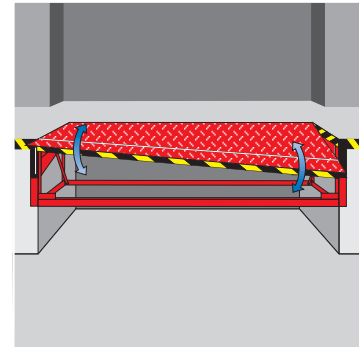

The platform is designed to compensate for canted truck beds and remains flush with the rear of the pit to eliminate pinch points.

## RITE-HITE Stationary Hydraulic Hinged lip leveller – CHKB-S 8000

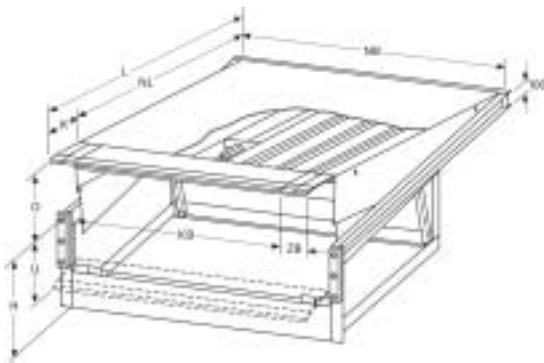

### Hydraulic

The hydraulic system lifts the platform into the required position. The hinged lip extends automatically to allow positioning on the loading floor of the trailer.

- NL - Nominal length
- K - Lip length
- L - Total length
- H - Leveller height
- O - Max. above dock position
- U - Max. below dock position
- NB - Nominal width
- KB - Lip width
- ZB - Width of the lip segments

### Available Configurations

#### Leveller surface finish:

- Standard Paint: Red RAL 3000  
Blue RAL 5010
- Optional: other RAL colours on request  
Galvanized steel finish

#### Surface platform:

- Standard: diamond tread plate
- Optional: abrasive ramp / noise reduction surface/  
insulated deck

#### Capacity:

- Standard 60 kN, optional 80 kN and 100 kN
- Other capacities are available on request

CHKB-S 8000						CHKB-S 8000		
NL (mm)	L (mm)	H (mm)	K (mm)	O (mm)	U (mm)	NB* (mm)	KB (mm)	ZB (mm)
2000	2400	620	400	320	320	1500	1500	-
2500	2900	620	400	365	360	1750	1750	-
3000	3400	700	400	460	340	2000	2000	-
3500	3900	700	400	530	350	2250	2000	125
4000	4400	700	400	600	350	2400	2000	2 x 100
4500	4900	700	400	670	350			

Sizes Hinge lip levellers CHKB-S 8000/CMKB-S 7000				
		NL (mm)		
		2000	2500	3000
NB (mm)	1500	Sz. 11	Sz. 12	Sz. 13
	1750	Sz. 21	Sz. 22	Sz. 23
	2000	Sz. 31	Sz. 32	Sz. 33
	2250	Sz. 41	Sz. 42	Sz. 43
	2400	Sz. 51	Sz. 52	Sz. 53

		NL (mm)		
		3500	4000	4500
NB (mm)	1500	Sz. 14	Sz. 15	Sz. 16
	1750	Sz. 24	Sz. 25	Sz. 26
	2000	Sz. 34	Sz. 35	Sz. 36
	2250	Sz. 44	Sz. 45	Sz. 46
	2400	Sz. 54	Sz. 55	Sz. 56

## RITE-HITE Stationary Mechanical Hinged lip leveller – CMKB-S 7000

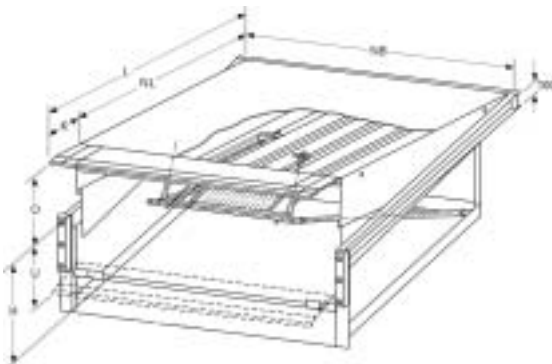

### Spring activated system

The platform is spring counterbalanced and can be easily operated by one person. The hinged lip extends automatically at the fully raised position and automatically stores after use. The leveller is manually brought back to its resting position.

- NL - Nominal length
- K - Lip length
- L - Total length
- H - Leveller height
- O - Max. above dock position
- U - Max. below dock position
- NB - Nominal width

CMKB-S 7000						
NL (mm)	L (mm)	H (mm)	K (mm)	O (mm)	U (mm)	NB* (mm)
2000	2400	620	400	320	320	1500
2500	2900	620	400	365	360	1750
3000	3400	700	400	460	340	2000

Remark Dock levellers in inch dimensions are available on request!

### How to order, example:

Hydraulic Hinge lip leveller

**CHKB-S 8000**

Leveller size: 2000 x 3000 mm

Article-Nr. **8000.33**  
Model Size

### How to order, example:

Mechanical Hinge lip leveller

**CMKB-S 7000**

Leveller size: 2000 x 3000 mm

Article-Nr. **7000.33**  
Model Size